



Emission Test System TS9976

Fully automatic emission measurements on wireless communication equipment

- Frequency range 0.15 MHz to 18 (40) GHz
- EMC measurements to IT standards (eg EN55022, FCC)
- Use in type approval testing (eg for GSM to ETS 300-607/609)
- Measurement of spurious emissions from radiocommunication equipment



ROHDE & SCHWARZ

Standard-conformal emission testing

Applications

System TS9976 is used for EMI and spurious emission measurements on wireless communication equipment during EMC and type approval testing. Typical DUTs are mobile phones, base stations, radio sets and short-range devices.

Relevant standards

Measurements of this type are based on the standards and technical regulations published by ETSI (European Telecommunications Standards Institute). For example, EMI measurements on GSM systems are defined by ETS 300-342, measurements of spurious emissions by ETS 300-607 (GSM 11.10), ETS 300-609 (GSM 11.20) and by TBR 5 and 9 (technical basis for regulation). ETS 300-339 provides the generic standard for the EMC of radio equipment.

Specified emission measurements

The above standards stipulate a wide variety of measurements in a very wide frequency range, all of which can be covered with TS9976:

- Conducted EMI measurements from 0.15 MHz to 30 MHz in line with EN55022
- Radiated EMI measurements from 30 MHz to 1000 MHz in line with EN55022
- Conducted spurious emission measurements from 100 kHz to 12.75 GHz on antenna connector of DUT

- Radiated spurious emission measurements from 30 MHz to 4 GHz

For some radiocommunication systems (eg short-range devices), higher frequency limits (eg 40 GHz) are already stipulated for spurious emission measurements. TS9976 can be modified accordingly to accommodate for this requirement.

Spurious emission measurements differ from EMI measurements to EN55022 mainly in that bandwidths matching the useful signal have to be set on the receiver instead of the typical EMC bandwidths (eg 200 Hz, 9 kHz, 120 kHz). It should also be noted that EMC bandwidths are referred to the 6 dB points of the IF filters, whereas the bandwidths for spurious emission measurements are

referred to the 3 dB points. In spurious emission measurements, the peak detector takes the place of the quasi-peak detector. All these differences make it necessary that for spurious emission measurements a spectrum analyzer or test receiver with spectrum analyzer functionality be used rather than a pure EMC test receiver.

In addition to EMI and spurious emission measurements, TS9976 can also measure useful signals, for example the EIRP (equivalent isotropically radiated power) of radio sets and modules with integrated antenna.

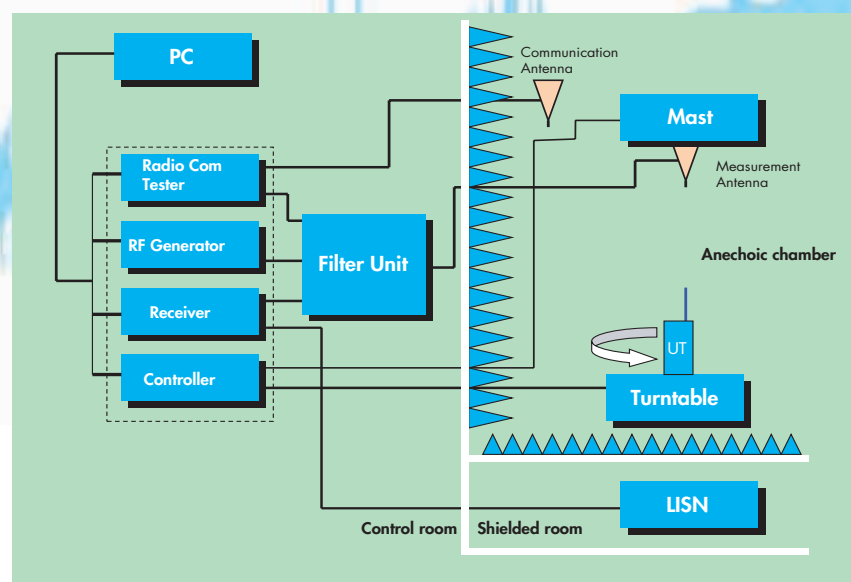

Fig. 1: Block diagram of TS 9976

System design

TS9976 comprises the following main components as shown in Fig. 1:

Test receiver

The test receiver forms the core of the system. As a typical EMC test receiver, it evaluates and displays emissions from 0.15 MHz to 1000 MHz in line with EN55022 and, in addition, it offers spectrum analyzer functionality for spurious emission measurements. If only the spurious is to be measured and if precompliance measurements are sufficient for EMC testing, a spectrum analyzer can be used instead of the test receiver.



Fig. 3: Filter unit incorporated in 19" rack. The relay plug-in and the three tunable bandstop filters are accommodated in the middle.

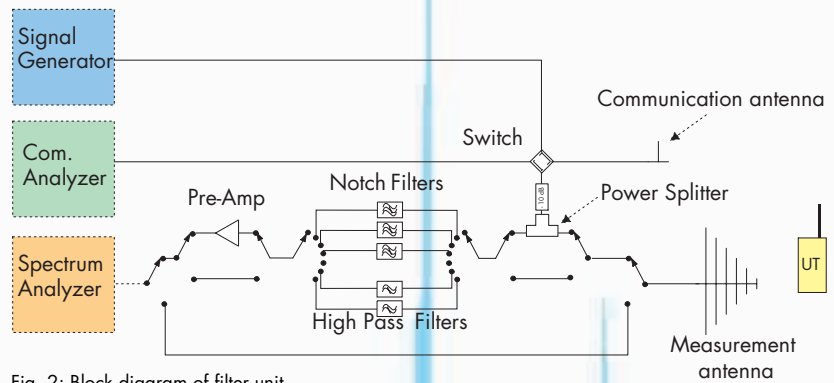

Fig. 2: Block diagram of filter unit

Test antennas

Suitable test antennas (usually log-periodic or horn antennas) and artificial mains networks are used for picking up emissions.

Anechoic chamber

Radiated emissions are measured in an anechoic chamber. For this, a remote-controlled turntable and an automatic antenna mast with a control unit are required. These components can optionally be supplied with the system and controlled by the system software.

Filter unit

To suppress the useful signal emitted by the DUT, a suitable filter must be connected ahead of the receiver input. This filter unit, which is incorporated in the system, is described in detail further below.

Communication tester

To switch the DUT to a defined operating state, a communication link has to be set up. This is done by a communication tester integrated in the system.

Signal generator

The signal generator is needed for system calibration and for substitution measurements which are prescribed by some standards.

Controller

The system components are controlled from a PC via the IEC/IEEE bus using EMI Software ES-K1 from Rohde & Schwarz.

Filter unit

To measure spurious emissions, for example of mobile phones, in line with standards at a sufficiently wide dynamic range also with the DUT transmitting, the useful signal emitted by the DUT must be suppressed by means of bandstop or highpass filters.

To this effect, Rohde & Schwarz developed a special filter unit which, thanks to its flexible design, satisfies the common mobile radio standards (GSM900, GSM1800, DECT, CDMA, etc) and at the same time meets customer-specific requirements. Fig. 2 shows the essential components of this filter unit in a block diagram. The filter unit in the system rack is shown in Fig. 3.

The receive signal (from the test antenna or a conducted measurement) can be switched to the various filters via a relay matrix. For measurements in the immediate vicinity of the useful signal carrier, three bandstop filters are provided. In addition, two high-pass filters are integrated for measuring the harmonics of the carrier frequency, for example. The filter unit in

its basic configuration incorporates filters allowing measurements on GSM900, GSM1800 and DECT systems. Filters for other standards can be fitted alternatively. A separate connector is provided for adding a user-specific filter.

System sensitivity can be enhanced by activating the preamplifier incorporated in the filter unit.

The signal generator output can be switched in for calibration of the overall system and for filter tuning. The connection between DUT and communication tester is likewise via the filter unit to enable conducted measurements.

The filter unit can be integrated in new systems and existing test setups.

Software

The control software (ES-K1), which forms part of the system, enables fully automatic simple testing. ES-K1 is characterized by the following features:

- Operation under Windows 95/98/NT
- Fully automatic, interactive measurements
- Evaluation of narrowband/broadband interference
- Automatic compensation of transducers (correction factors) and limit lines

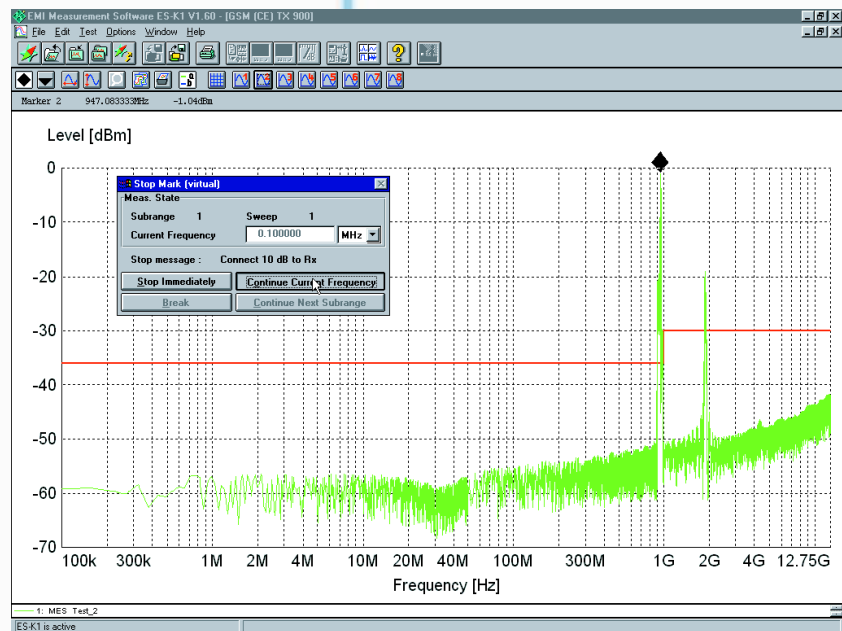

Fig. 4: Typical result display of emission measurement

- Test setup calibration
- Convenient and flexible result display and documentation (Fig. 4)

For more detailed information please refer to the ES-K1 data sheet. The complete software package runs on a PC or PC-compatible industrial controller. The system components are driven via the IEC/IEEE-bus interface.

Specifications

Test System TS9976

Operating temperature	+15 °C to +40 °C
Relative humidity	95% at 40 °C
AC supply	110 V, 230 V
Certification	CE, VDE

The system is supplied in a 19" rack

Filter unit

Electrical properties

Frequency range	DC to 18 GHz
Input impedance	50 Ω
Preamplifier gain	min. 20 dB (1 GHz to 18 GHz)
Max. number of bandstop filters	3
Max. number of highpass filters	2
Connector for user-specific filter	1 (DC to 18 GHz)

Available bandstop filters

Tuning range	
TETRA	380 MHz to 400 MHz
Modacom/SRD	414 MHz to 420 MHz
Paging/SRD	450 MHz to 484 MHz
CDMA/CDPD	824 MHz to 849 MHz
GSM 900 (uplink)	870 MHz to 915 MHz
GSM 900 (downlink)	925 MHz to 960 MHz
PDC	1400 MHz to 1500 MHz
DCS 1800/GSM1800	1700 MHz to 1800 MHz
DCS 1900/DECT	1800 MHz to 2000 MHz
WLAN	2400 MHz to 2500 MHz

Other filters on request

Electrical data

Insertion loss	typ. 1.5 dB except for edges of stop-band
VSWR	typ. 1.3
Stopband	depending on useful signal (eg 200 kHz, 1.23 MHz)
Stopband attenuation	min. 40 dB

Available highpass filters

1200 MHz:	
Insertion loss	typ. 1 dB
VSWR	typ. 2
Stopband attenuation	min. 40 dB at 630 MHz
1700 MHz:	
Insertion loss	typ. 1.5 dB
VSWR	typ. 2
Stopband attenuation	min. 40 dB at 1100 MHz
2800 MHz:	
Insertion loss	typ. 1.8 dB
VSWR	typ. 2
Stopband attenuation	min. 40 dB at 2050 MHz

Other highpass filters on request



Fax Reply (Emission Test System TS9976)

- Please send me an offer
- I would like a demo
- Please call me
- I would like to receive your free-of-charge CD-ROM catalogs

Others: _____

Name: _____

Company/Department: _____

Position: _____

Address: _____

Country: _____

Telephone: _____

Fax: _____

E-mail: _____



ROHDE & SCHWARZ